



Electromagnetic lock 5000N monitored



CHARACTERISTICS

- Compact and very complete surface mounted electromagnet
- Tamper protection: includes extra magnet on armature plate with signalling
- Also equipped with separate locking position signalling and LED indication
- LED is located behind a protective lens
- Secure fixing with included screws
- Standard for outward opening doors
- Positive security : quiescent current (FS) unlocked when de-energized
- Holding force magnet 5000N
- Suitable for control of movement of persons and for high-frequency use
- Less sensitive to structural imperfections
- Integration with any security installation
- Finishing gray powder coated aluminum body and with nylon coating
- Provides high resistance to oxydation
- 5 year warranty
- No residual magnetism after power failure
- No mechanical parts

TECHNICAL CHARACTERISTICS

- Weight: 4.71 kg
- Holding force: 5000N
- Magnet size: 266 x 67 x 40 (L x B x H in mm)
- Armature size: 185 x 61 x 16.5 (L x B x H in mm)
- Power supply: 12 – 24 VDC
- Power tolerance: + / - 10 %
- Current consumption: 240 mA @ 24 VDC,
420 mA @ 12 VDC
- Contacts: NO , NC , COM
- Operating temperature: -10 ~ +55°C

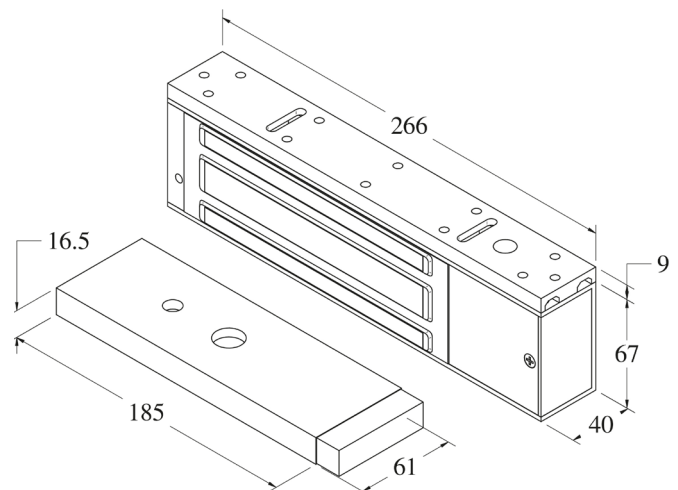

ORDER INFORMATION

- EM205210 - electromagnetic lock 5000N monitored