



SmartKing™ outdoor stainless steel surface mount electromagnet 3000N monitored



CHARACTERISTICS

- Stainless steel surface mount electromagnet
- Built-in monitoring
- Secure fixing with included screws and mounting plates
- Positive security: quiescent current (FS) unlocked when de-energized
- Holding force magnet 3000N
- Suitable for control of movement of persons and for high-frequency use
- Less sensitive to structural imperfections
- Integration with any security installation
- Provides high resistance to oxidation
- No residual magnetism after power failure
- No mechanical parts
- 5 year warranty

TECHNICAL SPECIFICATIONS

- Magnet size: 216 x 41 x 29 mm
- Armature size: 180 x 38 x 11 mm
- Holding force: 3000N
- Power supply: 12–24Vdc
- Current consumption: 420 mA \pm 10% @ 12VDC 210 mA \pm 10% @ 24VDC
- Contacts: 1 x NO/NC/COM contact
- Operating temperature: -10 to 55°C
- Weight: 2,31kg

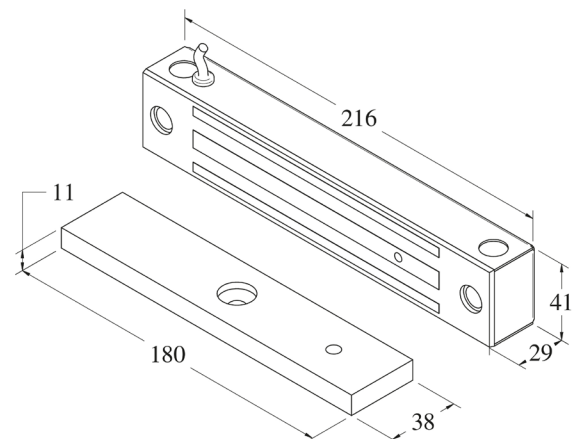

ORDER INFORMATION

- EM205510 - SmartKing™ outdoor stainless steel surface mount electromagnet 3000N monitored