



SmartKing™ outdoor stainless steel surface mount electromagnet 5000N monitored



CHARACTERISTICS

- Stainless steel surface mount electromagnet 5000N
- Secure fixing with included screws
- Positive security: quiescent current (FS) unlocked when de-energized
- Holding force magnet 5000N
- Suitable for control of movement of persons and for high-frequency use
- Less sensitive to structural imperfections
- Integration with any security installation
- Provides high resistance to oxidation
- No residual magnetism after power failure
- No mechanical parts
- 5 year warranty

TECHNICAL SPECIFICATIONS

- Magnet size : 222 x 62 x 42 mm
- Armature size: 185 x 61 x 16.5 mm
- Holding force: 5000 N
- Power supply: 12 – 24 VDC
- Current consumption: 420 mA \pm 10% @ 12VDC, 210 mA \pm 10% @ 24VDC
- Contacts: 1 x NO / NC / COM contact
- Operating temperature: -10 ~ +55°C
- Weight: 5,25 kg

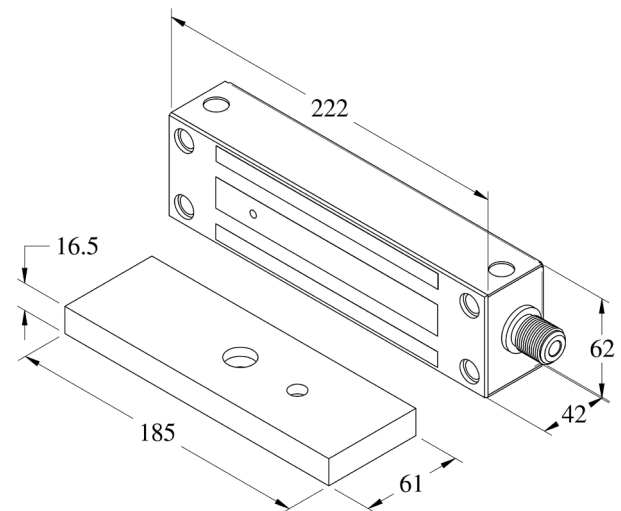

ORDER INFORMATION

- EM205611 - SmartKing™ outdoor stainless steel surface mount electromagnet 5000N monitored