



SmartKing™ outdoor stainless steel surface mount electromagnet 8000N monitored



CHARACTERISTICS

- Stainless steel surface mount electromagnet
- Built-in monitoring
- Secure fixing with included screws and mounting plates
- Positive security: quiescent current (FS) unlocked when de-energized
- Holding force magnet 8000N
- Suitable for control of movement of persons and for high-frequency use
- Less sensitive to structural imperfections
- Integration with any security installation
- Provides high resistance to oxidation
- No residual magnetism after power failure
- No mechanical parts
- 5 year warranty

TECHNICAL SPECIFICATIONS

- Magnet size: 222 x 61 x 45 mm
- Armature size: 185 x 61 x 16 mm
- Holding force: 8000N
- Power supply: 12–24Vdc
- Current consumption: 480 mA \pm 10% @ 12VDC 240 mA \pm 10% @ 24VDC
- Contacts: 1 x NO/NC/COM contact
- Operating temperature: -10 to 55°C
- Weight: 5,5 kg

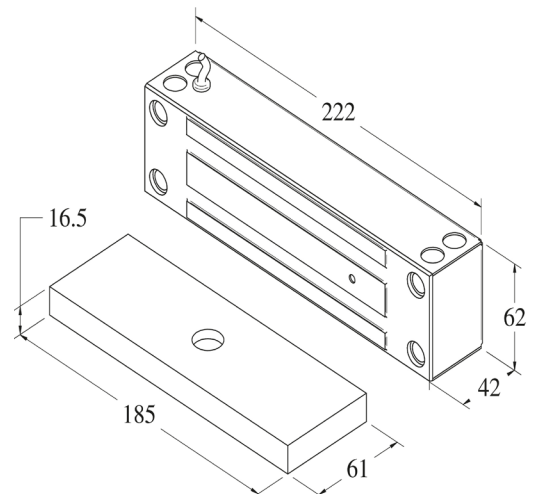

ORDER INFORMATION

- EM205710 - SmartKing™ outdoor stainless steel surface mount electromagnet 8000N monitored